

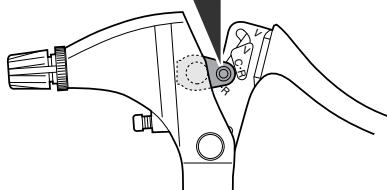

## WARNING

- It is important to completely understand the operation of your bicycle's brake system. Improper use of your bicycle's brake system may result in a loss of control or an accident, which could lead to severe injury. Because each bicycle may handle differently, be sure to learn the proper braking technique (including brake lever pressure and bicycle control characteristics) and operation of your bicycle. This can be done by consulting your professional bicycle dealer and the bicycle's owners manual, and by practicing your riding and braking technique.
- The SB-7S45/BL-IM45 brake levers are equipped with a mode switching mechanism. Be sure to use the BR-IM41-F with the mechanism in the C.R mode position.

### C.R mode position



The C indicates the mode position for compatibility with cantilever brakes.  
The R indicates the mode position for compatibility with roller brakes.

- Obtain and read the service instructions carefully prior to installing the parts. Loose, worn, or damaged parts may cause serious injury to the rider.  
We strongly recommend only using genuine Shimano replacement parts.

## SERVICE INSTRUCTIONS

SI-22V0G

# Front Inter-M Brake System

Before use, read these instructions carefully, and follow them for correct use.

# SHIMANO® NEXUS

In order to realize the best performance from the Shimano front Inter-M brake system, we recommend that the following combination be used.

Brake	Hub	Lever	Brake cable
BR-IM41-F	HB-NX50-NT HB-IM40	SB-7S45 BL-IM45	
		SB-4S35 BL-IM33	
		SB-3S30 BL-IM32	
		SB-4S30 BL-IM30	
		BL-IM36	

\* Use the BR-IM41-F front brake unit in conjunction with a nut-type hub.

## CAUTION

1. The Shimano Inter-M brake system cannot be used with mountain bikes. Furthermore, when using this brake system with other kinds of bikes, avoid continuous application of the brakes when riding down long slopes, as this will cause the internal brake parts to become very hot, and this may weaken braking performance. It may also cause a reduction in the amount of brake grease inside the brake, and this can lead to problems such as abnormally sudden braking.  
The design of the Shimano Inter-M brake system has been carried out based on standards such as ISO 4210 and DIN 79100-2. These standards specify the performance for an overall weight of 100 kg. If the overall weight exceeds 100 kg, the braking force provided by the system may be insufficient for correct braking, and durability of the system may also be reduced.
2. The front Inter-M brake system should only be installed to the left side of a bicycle which is 26" or larger. If it is used on a bicycle which is smaller than 26", the braking force may be too great, which could cause accidents.
3. In order to get the best performance from the Shimano front Inter-M brake, be sure to use Shimano brakes cables and brake levers as a set. (Refer to the product line-up.)

(The amount of movement of the inner cable must be 14.5 mm or more when the brake lever is depressed. If it is less than 14.5 mm, braking performance will suffer, and the brakes may fail to work.)

4. Check that the front brake unit is firmly secured to the hub body with the brake unit fixing nut.

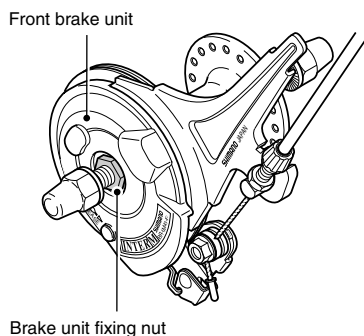

**Tightening torque:**  
15 – 20 Nm {130 – 174 in. lbs.}

5. Check that the hub axle is touching the back of the fork end, and that the end of the brake arm is protruding 1 mm or more from the brazed-on bracket of the front fork. Check also that the wheel is firmly secured to the frame with the cap nut. If the wheel is not installed properly, it may come off the frame, which could result in serious accidents when riding.

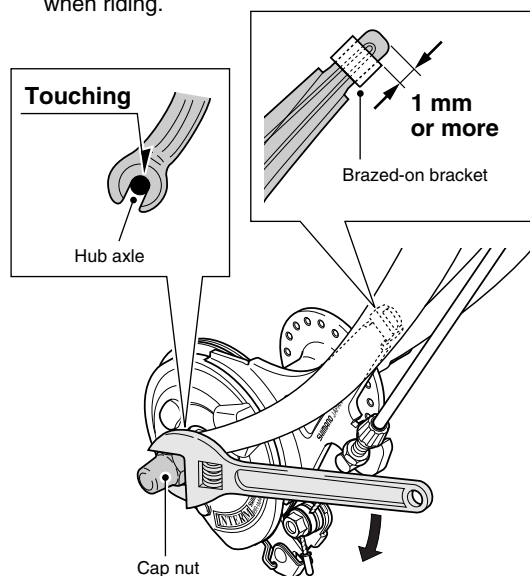

**Tightening torque:**  
30 – 45 Nm {260 – 390 in. lbs.}

6. If any of the following occur while using the brakes, stop riding immediately and ask the place of purchase to carry out inspection and repairs.

- 1) If abnormal noise is heard when the brakes are applied
- 2) If braking force is abnormally strong
- 3) If braking force is abnormally weak

In the case of 1) and 2), the cause might be not enough brake grease, so ask the place of purchase to grease the mechanism with special roller brake grease.

7. If the brakes are used frequently, the brake drum may become hot. Do not touch the brake drum for at least 30 minutes after you finish riding the bicycle.

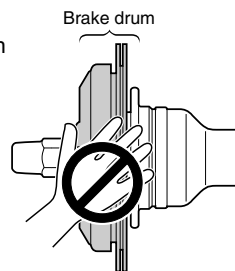

8. If the brake cable becomes rusted, braking performance will suffer. If this happens, replace the brake cable with a genuine Shimano brake cable and re-check the braking performance.
9. The BR-IM41-F front brake unit and HB-NX50-NT/ HB-IM40 front hub unit should never be disassembled. If they are disassembled, malfunctions and damage to the front brake unit and front hub unit could result.
10. Consult the place of purchase for details on removing and installing the front brake unit.

#### NOTE:

- Use a wheel with 3x or 4x spoke lacing. Wheels with radial lacing cannot be used because the spokes and the wheel can be damaged when applying the brakes and brake noise can be generated.
- The front Inter-M brake is different from conventional band brakes in that the inside of the brake drum is filled with grease. This may cause the turning of the wheel to be slightly heavier than usual, particularly in cold weather.
- The front Inter-M brake has a built-in power modulator which controls the braking force applied to the hub. Noise is generated by the operation of the power modulator when the brake is applied, but this is not a sign of a malfunction.
- If you apply the front Inter-M brake strongly while the bicycle is stopped and then shake the wheel, you will notice that there is a small amount of play in the brakes. This is normal, and will not cause any problems at all while riding.
- To check the amount of looseness in the head parts, grasp the middle of the handlebar and one of the front forks as shown in the illustration, and then move the head parts back and forth in the directions indicated by the arrows.

Moreover, because the brakes give a small amount of play if you apply the brakes fully and shake the wheel as described above, this will make it more difficult to check the looseness in the head parts.

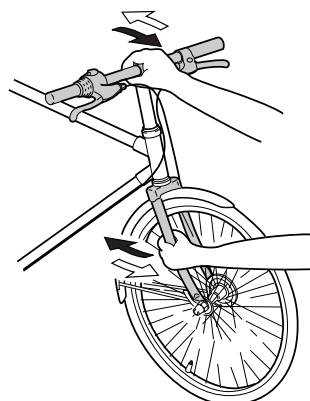

- For maximum performance we highly recommend Shimano lubricants and maintenance products.

## Disconnecting the brake cable from the front brake unit

1. Push the link back until it stops. Then slide the inner cable fixing bolt unit along the guide hole and remove it from the hole. If the inner cable fixing bolt unit is difficult to remove, turn the cable adjusting bolt clockwise to loosen the cable tension and then remove the inner cable fixing bolt unit.

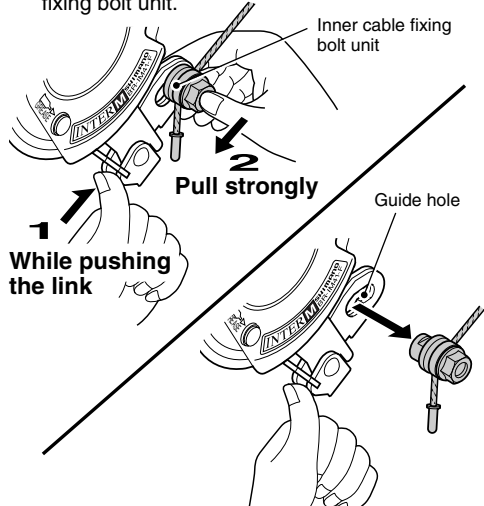

2. Slide the outer casing holder along the guide slot in the brake arm to remove it from the slot.

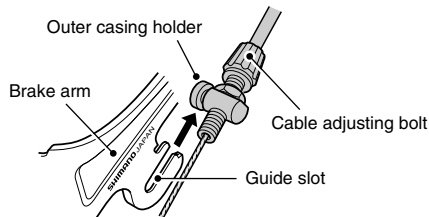

To install the brake cable again, carry out the above procedure in reverse.

### Note:

- While looking from the rear of the link, check that the inner cable fixing bolt unit is firmly seated in the position shown in the above illustration.

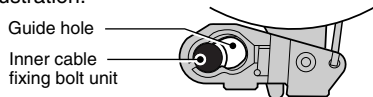

- Depress the brake lever to check the braking performance. If the braking performance is poor, adjust the brake cable once more while referring to "Adjusting the brake cable".

## Installing the brake cable

1. While depressing the brake lever, pass the brake cable set through the hole in the bracket.

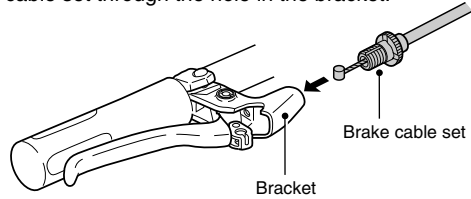

2. Align the inner cable end with the hole in the cable hook, and then turn the cable hook as shown in the illustration and insert the inner cable end into the hole.

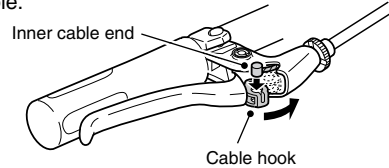

3. Slide the outer casing holder along the guide slot in the brake arm to set it into the slot.

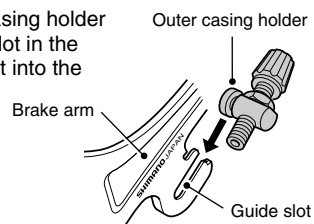

4. While holding the link to secure it so that it does not move, slide the inner cable fixing bolt unit along the guide hole to install it.

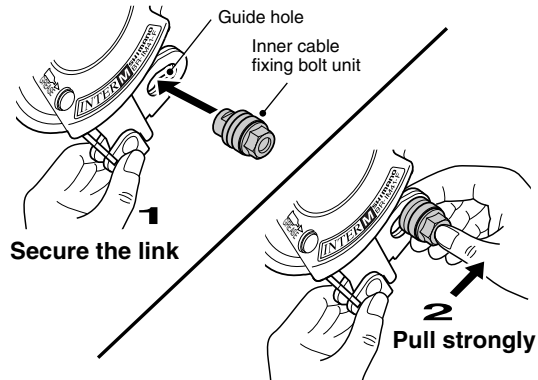

### Note:

While looking from the rear of the link, check that the inner cable fixing bolt unit is firmly seated in the position shown in the above illustration.

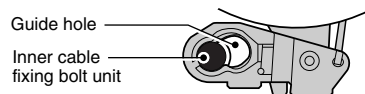

- Place the cable adjusting bolt so that it is 20 – 22 mm from the end of the outer casing holder, and then pass the inner cable through the cable adjusting bolt and then through the hole in the inner cable fixing bolt.

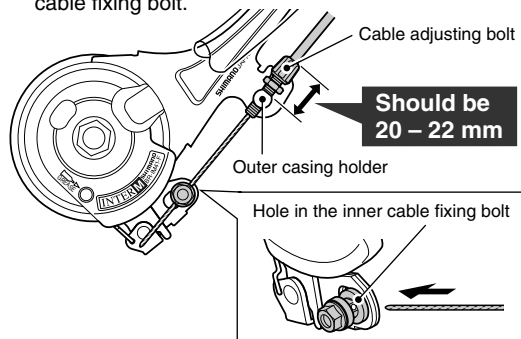

- Check that both ends of the outer casing are securely inserted into the cable adjusting bolts of both the brake lever and brake arm.

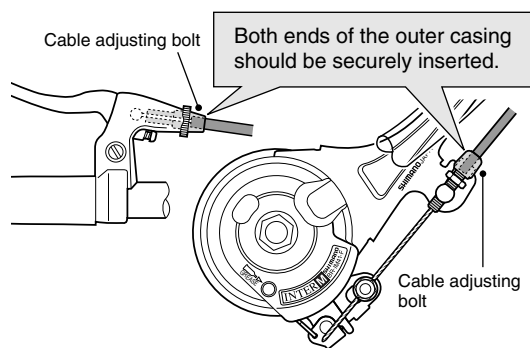

- Push the link back until it stops. Then, while pulling the inner cable to apply the full amount of tension to the cable, tighten the inner cable fixing nut.

**Tightening torque:**  
6 – 8 Nm {52 – 69 in. lbs.}

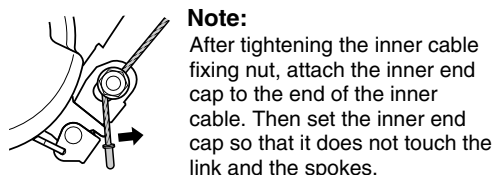
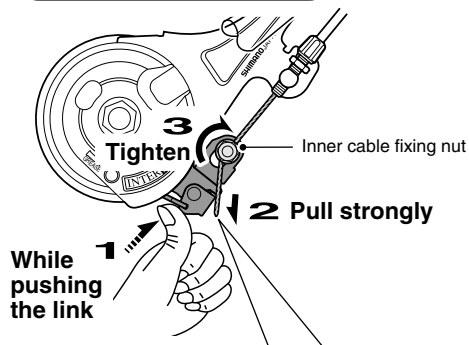

## Adjusting the brake cable

- After checking that the wheel does not easily turn while the brake cable is being pulled, depress the brake lever about 10 times as far as the grip in order to run in the brake cable.

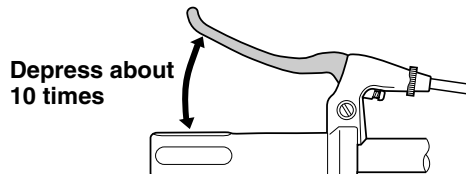

**Note:**

If the brake cable is not run in, it will need to be adjusted again after only a short period of use.

- Turn the cable adjusting bolt or nut of the brake unit or brake lever so that there is about 15 mm of play in the brake lever.

(The amount of brake lever play is the distance from the position where the brake lever is not operated to the position where a force is felt suddenly when the brake lever is pulled.)

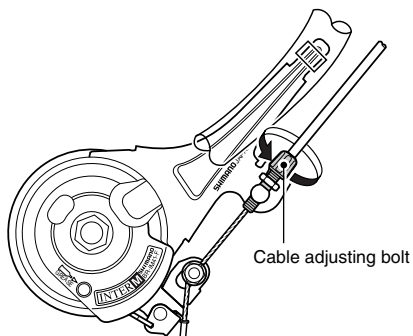
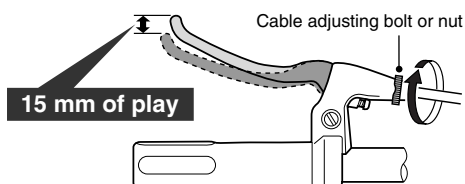

- After depressing the brake lever to check the braking performance, secure the cable adjusting bolt with the cable adjusting nut.

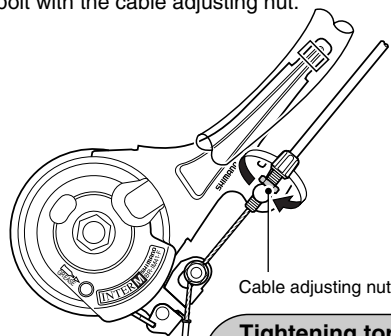

**Tightening torque:**  
1 – 2 Nm  
{9 – 17 in. lbs.}

These service instructions explain how to use and maintain the Shimano bicycle parts which have been used on your new bicycle. For any questions regarding your bicycle or other matters which are not related to Shimano parts, please contact the place of purchase or the bicycle manufacturer.

These service instructions are printed on recycled paper.

Please note: Specifications are subject to change for improvement without notice. (English)

# SHIMANO®

**SHIMANO AMERICAN CORPORATION**  
One Holland Irvine CA 92618 U.S.A. Phone 949-951-5003

**SHIMANO EUROPA**  
Industrieweg 24 NL-8071 CT Nunspeet, Holland Phone 31-341-272222

**SHIMANO INC.**  
3-77 Oimatsucho, Sakai, Osaka, Japan Phone 072-223-3243

© Oct. 2001 by Shimano Inc. PIT. SZK. Printed in Japan

